

## IMPORTANT

**READ THESE INSTALLATION INSTRUCTIONS CAREFULLY** before attempting to install the IC-A200 in an aircraft. This sheet contains important safety instructions for the IC-A200.

**NEVER** install the transceiver where normal navigation of the aircraft may be hindered.

**NEVER** install an antenna near any aircraft projection, engine, or propeller.

**INSTALL** a circuit breaker between the aircraft battery and the IC-A200.

**NEVER** install the transceiver in an aircraft with a 24 V battery. The transceiver operates with 13.8 V DC.

Check operation after installation.

Protect channel content **CANNOT** be changed by a customer.

## INSTALLATION PROCEDURE

Install the IC-A200 according to the following procedure.

- ① Check the quantity of parts. Refer to UNPACKING.
- ② Prepare miscellaneous items required for installation. Refer to MISCELLANEOUS ITEMS.
- ③ Prepare required wiring. Refer to MOLEX CONNECTOR ASSEMBLY, COAXIAL CABLE ASSEMBLY and WIRING.
- ④ Assemble supplied mounting bracket and other parts. Refer to RACK MOUNT ASSEMBLY.
- ⑤ Cut the mounting hole. Refer to MOUNTING HOLE.
- ⑥ Mount the IC-A200 into the mounting bracket. Refer to RACK MOUNTING.
- ⑦ Check the IC-A200 operation. Refer to OPERATION CHECK.
- ⑧ Set protect channels, if required. Refer to MEMORY PROTECTION.

## UNPACKING

The following parts are supplied with the IC-A200. Inspect the quantity of each part carefully.

Make sure you have received all parts and that there is no shipping damage.

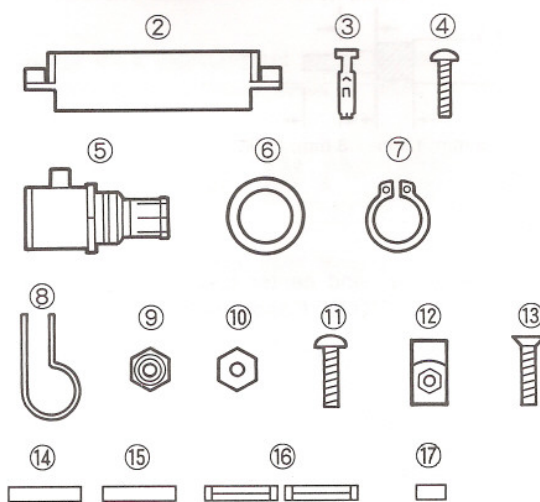
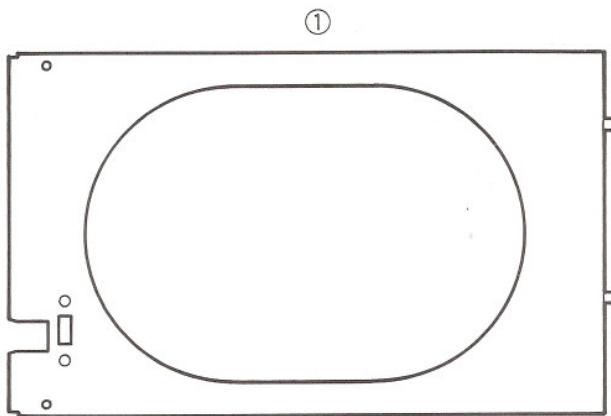

①	Mounting bracket.....	1
②	Molex connector (4338-15).....	1
③	Molex terminals (4366-GL).....	30
④	Screws (No. 4 × 1/2).....	2
⑤	BNC L-shaped antenna connector.....	1 set
⑥	Washer (Icom washer V).....	1
⑦	C-shaped ring.....	1
⑧	Antenna cable clip.....	1
⑨	Self-crimping nut (No. 6).....	1

⑩	Nut (No. 6).....	1
⑪	Screw (No. 6 × 1/2).....	1
⑫	Crimp nuts (No. 6).....	6
⑬	Screw (No. 6 × 1/2).....	6
⑭	COMM1 sticker.....	1
⑮	COMM2 sticker.....	1
⑯	Fuses (5 A).....	2
⑰	Molex polarizing key.....	1

## MISCELLANEOUS ITEMS

The following items are required for installation but are **NOT** supplied with the IC-A200.

- ① VHF air band antenna for the communication band.
- ② Cables.
- ③ Switches are mounted on the aircraft yoke.
- ④ 500  $\Omega$  headphones.
- ⑤ Low-impedance carbon or dynamic microphone.
- ⑥ Preamplifier for a dynamic microphone.

## BATTERY CONNECTION

**NEVER** install the transceiver into an aircraft with a 24 V battery. The transceiver operates with 13.8 V DC.

**NEVER** connect the transceiver to a power source using reverse polarity. This connection damages the transceiver.

To prevent voltage drops, solder or crimp the cable lug when connecting the DC power cable to the power supply.

## TRANSCIEVER LOCATION

Select a location which can support the weight of the transceiver.

**NEVER** place the transceiver where normal navigation of the aircraft may be hindered or where it could cause bodily injury.

**NEVER** bend the cables sharply or place the cables too near the aircraft control cables.

**DO NOT** place the transceiver where hot or cold air blows directly on it.

**AVOID** placing the transceiver in areas with temperatures below  $-20^{\circ}\text{C}$  or above  $+55^{\circ}\text{C}$ .

## ANTENNA

**NEVER** install an antenna near any aircraft projection, engine or propeller.

Use a 50  $\Omega$ , vertically-polarized, VHF air band antenna.

VSWR should be less than 3 : 1.

Mount the antenna on a flat metal surface or install a ground plane of at least 120  $\text{cm}^2$  (18  $\text{in}^2$ ).

## INTERCOM

The intercom function is available by wiring and installing a yoke-mounted communication/intercom switch. This function facilitates swift contact between the pilot and co-pilot. 2-pairs of headphones and microphones are required for pilot and co-pilot.

## INTERLOCK

If 2 transceivers are installed in your aircraft, wiring for a transmit/receive interlock is required.

To protect the receiver circuit from extremely strong signals, this function prevents receiving while another transceiver is transmitting.

## COMM1 AND COMM2 STICKERS

When 2 transceivers are installed, to distinguish them from one another, attach the supplied COMM1 and COMM2 stickers.

COMM1 or COMM2 sticker

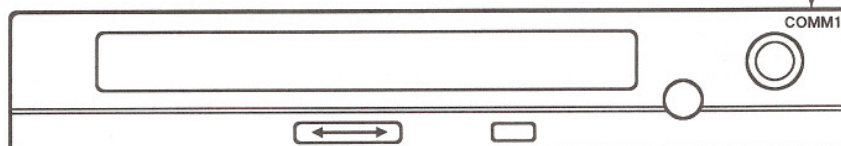

# RACK MOUNT ASSEMBLY

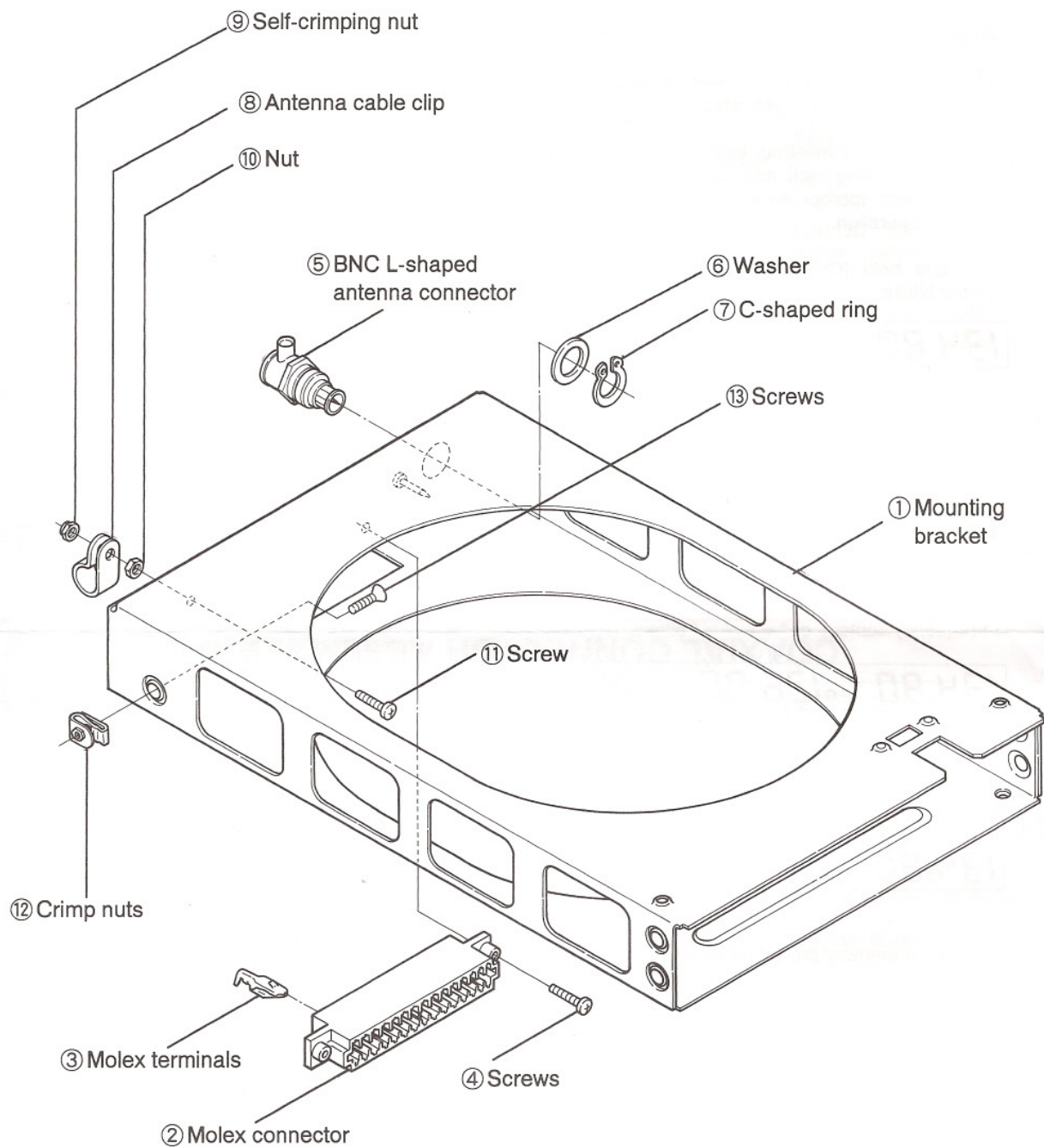

# MOUNTING HOLE

## ■ Notes for making the mounting hole

The IC-A200 can be mounted securely in the supplied mounting bracket.

Remember to allow adequate space for installation of cables and connectors.

When installing 2 or more transceivers in a stack, the mounting trays should be 1.27 mm (0.05 in) apart.

The mounting bracket has 0.64 mm (0.025 in) dimples built in to the top, the bottom and both sides for proper spacing.

Mark and cut the mounting holes.

To support the mounting bracket, the rear mounting bosses should be attached to the airframe.

## ■ Mounting rack dimensions

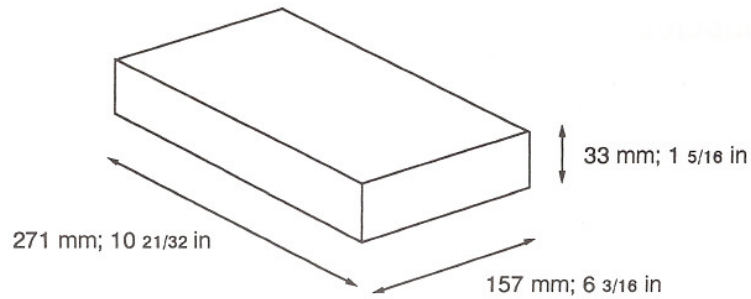

## ■ Hole dimensions

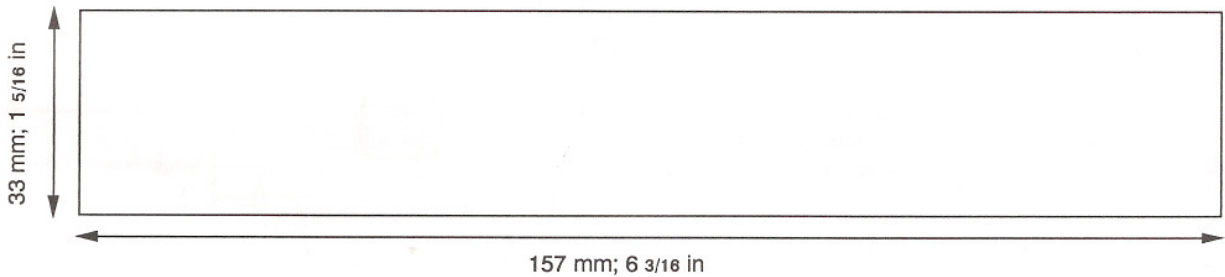

Cut out dimensions for the mounting rack as above.

## ■ Front panel dimensions

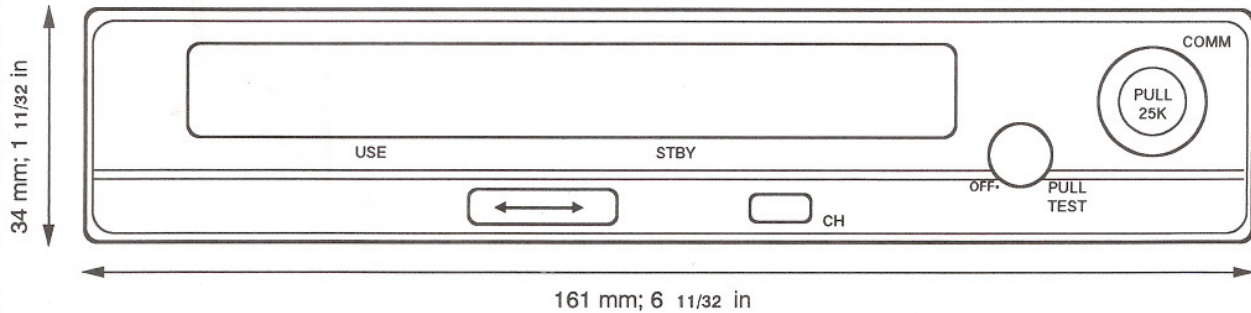

Allow space for the front panel as above.

# WIRING

## Power cable wiring

Use 2 pairs of #18 AWG wires for power and power grounding wiring.

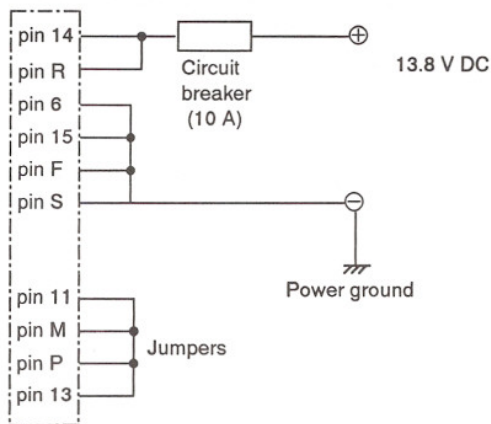

### Circuit breaker

To prevent physical damage, a 10 A circuit breaker **MUST** be installed in the aircraft. Mount the circuit breaker in the aircraft breaker panel or instrument panel to ensure easy access during flight.

### Ground

The transceiver power ground is the airframe ground.

### Jumpers

Pins 11, M, P, 13 **MUST** be jumped together with AWG #20 wires or thicker.

## Internal fuse

The IC-A200 has a 5 A internal fuse. If the power does not turn ON, open the top cover and check the fuse.

## Dimmer selection

Connect pin B to the instrument panel lighting line.

When the instrument panel lighting switch is placed to dimmer position, the transceiver backlighting is reduced to half brightness.

## Molex connector

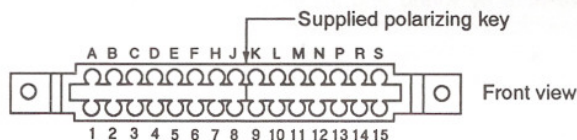

A	No connection	M	+ 13.8 V power (input)	6	Power ground
B	+ 14 V lighting (input)	N	Transmit/receive interlock	7	Ground for pin H
C	Auxiliary audio 2 (input)	P	Switched aircraft power (output)	8	Ground for pins J, K, 9
D	Auxiliary audio 1 (input)	R	Aircraft power (input)	9	PTT*
E	4 Ω audio (output)	S	Power ground	10	Squelch cancel*
F	Power ground	1	Ground for pin B	11	+ 13.8 V power (input)
H	500 Ω audio (output)	2	Detected audio (output)	12	Frequency exchange switch*
J	Comm microphone (input)	3	Auxiliary audio 3 (input)	13	Switched aircraft power (output)
K	Intercom microphone (input)	4	Ground for pins D, C, 3	14	Aircraft power (input)
L	Memory channel switch*	5	Ground for pin E	15	Power ground

\*Ground to activate.

## Audio wiring

Use #24 AWG wires for connectors.

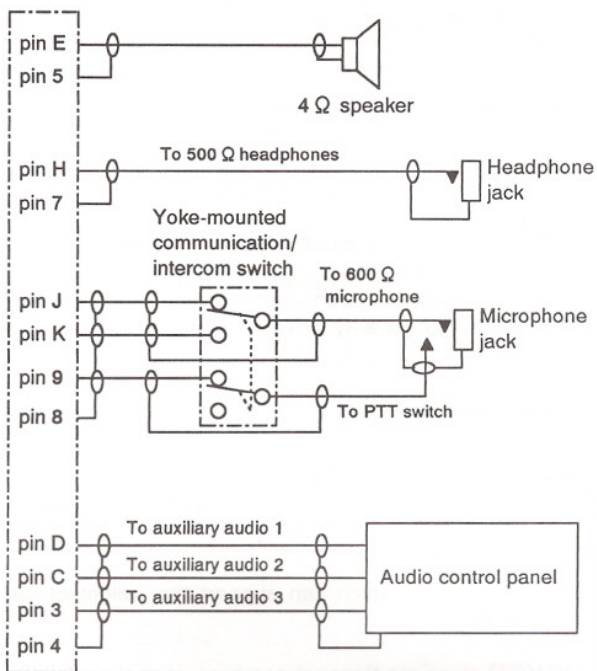

## Yoke-mounted channel and frequency exchange switches

For the yoke-mounted channel switch and frequency exchange switch, use a 2-position spring loaded rocker switch or 2 separate momentary push switches.

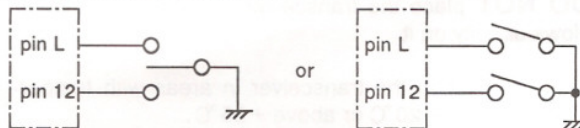

## Transmit/receive interlock wiring

When 2 transceivers are installed and both communication antennas are top mounted, pin N **MUST** be connected to pin 9 of each another transceiver.

## MOLEX CONNECTOR ASSEMBLY

The IC-A200 mates with a Molex connector in the rack mount. Assemble the Molex connector as follows.

### ■ Contact terminal assembly

- 1) Strip 4 mm (0.16 in) from each wire for the contact terminal.
- 2) Open the HTR-6115 Molex hand crimper with the engraved side toward you.
- 3) Insert the stripped conductor until the insulation is even with the side of the crimper facing you.
- 4) Clip the conductor tab until a crimp is obtained.
- 5) Move the lead to the crimper anvil.
- 6) Place the insulating tab section on the crimper anvil.
- 7) Crimp again until a sufficient crimp is obtained.

### ■ Contact insertion

Insert the contact terminals into the proper location in the connector housing. Push the terminal until a click is heard.

### ■ Polarizing key

Before installing the Molex connector into the mounting rack, check the polarizing key position between contacts 8 and 9. Refer to Connector front view in WIRING at left.

### ■ Contact extraction

Use the Molex contact ejector tool.

- 1) Slip the flat narrow blade of the contact ejector tool under the contact on the mating side of the connector.
- 2) Turn the connector upside down to slide the blade into the stop.
- 3) When the blade is fully in, pull the lead using moderate pressure.
- 4) Before reinstalling, make sure the tab extends as in the figure below.

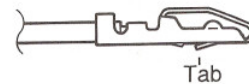

## COAXIAL CONNECTOR ASSEMBLY

- 1) Strip the RG-58 coaxial cable. Soft solder the shield and center conductor independently.

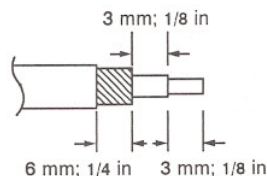

10 mm  $\approx$  3/8 in

- 2) Solder the shield and center conductor to the coaxial connector. **DO NOT** apply excessive heat.

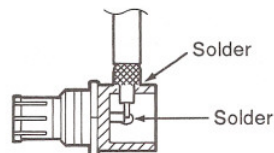

- 3) After soldering, install a ring and a cap.

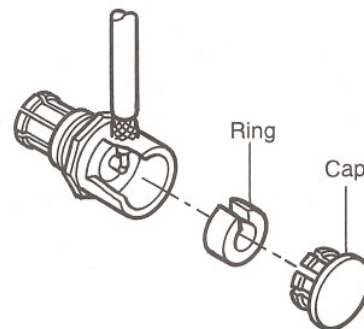

## OPERATION CHECK

Check the following points after transceiver installation.

- Polarity of the power supply.
- **NO** interference caused to other equipment.
- **NO** noise or interference from other equipment.
- VSWR is less than 3 : 1.
- Communication capability on both the highest and lowest communication frequency, if possible.

## RACK MOUNTING

### ■ Transceiver installation

- 1) Visually confirm that the metal catch on the top of the transceiver is as shown in Fig. 1.
- 2) Slowly insert the transceiver into the mounting rack.
- 3) Insert a 3/32 in allen wrench into the hole in the front panel.
- 4) Rotate the wrench clockwise until the screw stops.
  - **DO NOT** overtighten the screw.

### ■ Transceiver removal

The IC-A200 is easily removed from the mounting rack, if required.

- 1) Insert a 3/32 in allen wrench into the hole in the front panel as shown in Fig. 2.
- 2) Rotate the wrench counterclockwise until the front panel moves slightly from the mounting rack as shown in Fig. 2.
- 3) Slowly pull the transceiver out from the mounting rack.

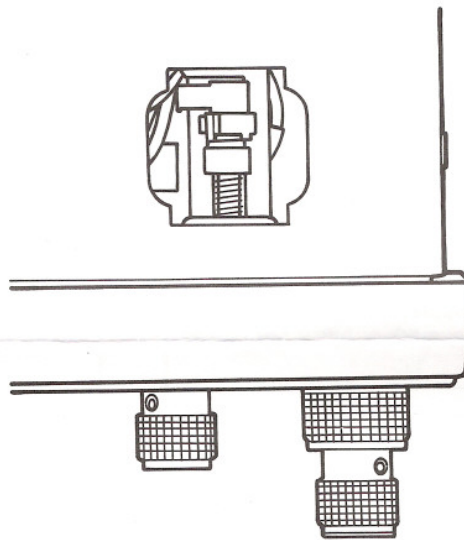
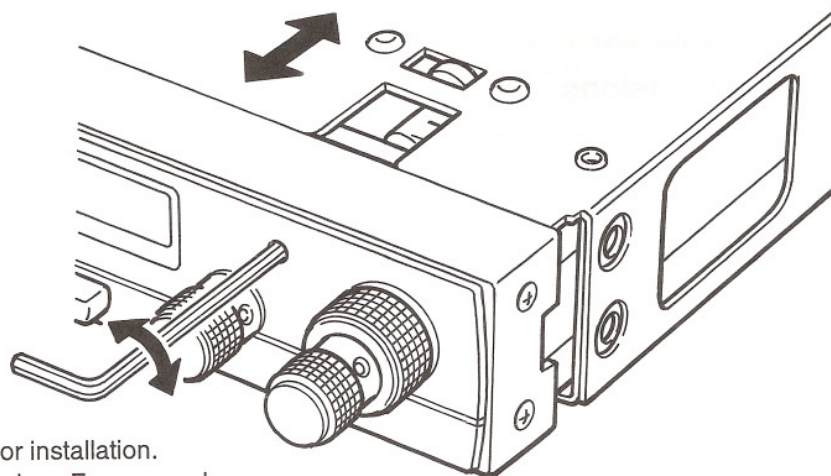

Fig. 1



Clockwise : For installation.  
Counterclockwise : For removal.

Fig. 2

## MEMORY PROTECTION

To prevent accidental changes, required memory channels can be specified as protect channels. The contents of protect channels **CANNOT** be changed by a user.

### Memory protection programming

**NOTE: DO NOT** push and hold [↔] in steps 4), 7) and 9), or other functions are activated.

- 1) Before setting or cancelling, extract the transceiver from the mounting rack and open the top cover. Then connect appropriate connector to the transceiver for operation.

- 2) Push and hold [CH] until the memory channel number blinks.



- 3) Rotate the large or small tuning knob to select a memory channel to be programmed as a protect channel.



- 4) Push [↔].
  - Frequency content or "-----" blinks.



- 5) Rotate the large and small tuning knobs to select a desired frequency.

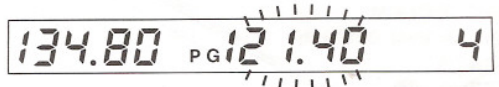

- 6) Ground the memory protection pin (J7 on the MAIN UNIT).

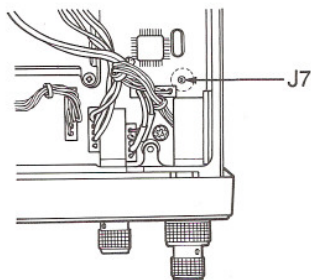

- 7) Push [↔].

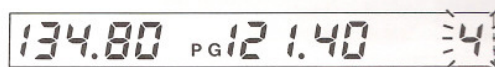

- 8) Unground the memory protection pin.
  - The memory channel is now programmed as a protect channel.

- 9) Confirm that the frequency content **DOES NOT** blink even when [↔] is pushed.



### Memory protection cancelling

**NOTE: DO NOT** push and hold [↔] in steps 4), 6) and 7), or other functions are activated.

- 1) Push and hold [CH] until the memory channel number blinks.

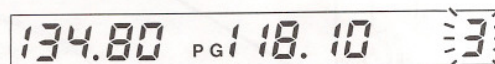

- 2) Rotate the large or small tuning knob to select a protect channel to be cancelled.

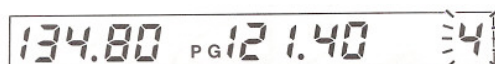

- 3) Ground the memory protection pin as shown in the diagram at left below.

- 4) Push [↔].
  - Frequency content blinks.

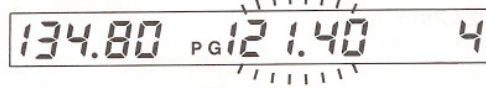

- 5) Unground the memory protection pin.

- 6) Push [↔].
  - The memory protection is now cancelled.



- 7) Confirm that the frequency content blinks when [↔] is pushed.

